

Big Blue®

High Performance Fireproofing Pump and Mixer



Big Blue®



Electric model shown,
gasoline model also available

- Ideal for short and long distance pumping
- 102 hp (75kW) turbo-charged engine
- Optional 16 ft³ (453L) paddle mixer

Designed for both short and long distance pumping applications, Big Blue offers smooth, controllable output. This versatile model can also handle a wide variety of fireproofing jobs. Equipped with our patented “adjustable pulsation control,” Big Blue ensures an even flow for less nozzleman fatigue and reduced hose wear.

The optional 16 ft³ (453L) hydraulic drive paddle mixer handles a vast array of materials. Both pump and mixer run off the unit’s powerful 102 hp (75kW) turbo-charged Deutz engine.

Big Blue® Specifications

Performance	
Max volume output	21 yd ³ /hr (16m ³ /hr) 130+ bags/hr (MK-6)
Max pumping pressure	2000 psi (138 bar)
Volume control	Variable 0 to full
Technical Information	
Type	Ball and seat with hydraulic drive
Material cylinders	4" (100mm)
Stroke length	39" (1000mm)
Strokes per minute	35 max
Hopper capacity	20 ft ³ (566L)
Hopper height	41" (1041mm)
Outlet diameter	3" threaded (76mm)
Hydraulic capacity	35 gallon (132L)
Engine	
Manufacturer's model	Deutz BF4M2012
Horsepower	102 hp (75kW)
Fuel tank capacity	26 gallon (98L)
Trailer	
Axle	Tandem
Axle Capacity	8000 lbs (3629kg)
Tires	LT 235/85R16G
Brakes	Electric
Outriggers	Manual
Dimensions — without Mixer	
Length	197" (5004mm)
Width	72" (1829mm)
Height	70" (1778mm)
Weight (approx)	5760 lbs (2615kg)

Maximum theoretical values listed. Pumping distances shown were calculated at the maximum volume output. They are to be used as a guide only and can be exceeded on specific projects. Maximum attainable distances depend on concrete mix design, pipeline diameter and specific job site conditions. Note: Maximum output and pressure cannot be achieved simultaneously. Specs subject to change without prior notice. Photos for illustrative purposes only. Refer to Putzmeister's operator manual for safe and proper equipment operation.



Putzmeister America, Inc.
1733 90th Street
Sturtevant, WI 53177 USA
Telephone (262) 886-3200
(800) 884-7210
Facsimile (262) 884-6338
www.putzmeister.com



Authorized Distributor

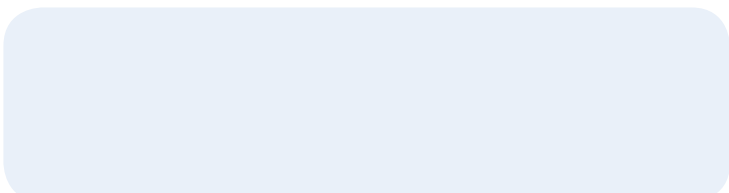

Standard Features

- Fully enclosed weatherproof control panel
- Electric on/off/volume remote control
- Variable displacement axial piston pump
- Cast steel, heavy-duty manifold
- 24 CFM (680 L/min) air compressor
- Hard chromed material cylinders
- Galvanized steel hopper
- Complete spray nozzle assembly
- High quality paint finish — blue and cream

Options (Consult factory for more options.)

- CM-150 mixer
- CM-150 hydraulic kit
- Grace paddle kit
- 16 ft³ paddle mixer
- Electric versions

CM-150 Mixer (Optional)

- Continuous feed with water metering system
- 150 bags/hr (MK-6)
- 14 ft³ (396L) bin capacity w/low material shutdown
- Infinitely variable water/material ratio
- Powered hydraulically from the Big Blue (requires CM-150 hydraulic kit)

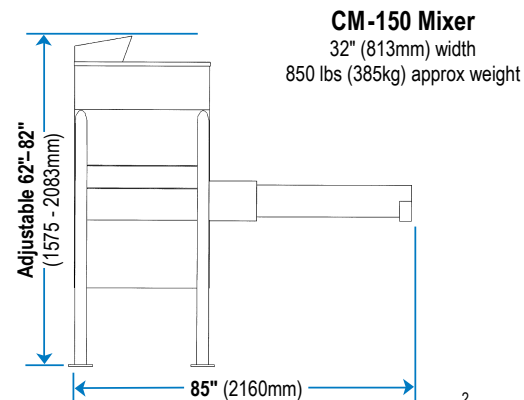

16 ft³ Paddle Mixer (Optional)

- 16 ft³ (453L) capacity/5 bags (MK-6)
- Grace paddle kit included
- Hydraulically powered mixing and unloading
- Transport and storage covers included
- Dustless fill chute included